

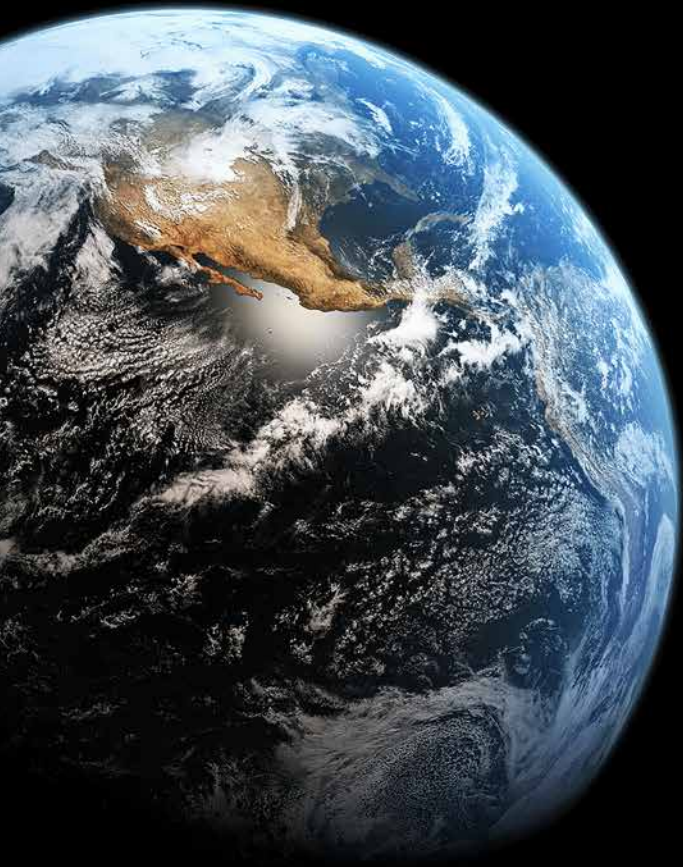

Mobile Machines

The realization that natural resources are finite has pushed people into thinking about their lifestyle. This is why we are now more attuned to the idea of nature being a valuable asset that needs to be safeguarded for future generations. The development of sustainable solutions is the active way to contribute to a future worth living, and is something that our employees engage in on a day-to-day basis.

Karlgünter Eggersmann,  
CEO



# Navigation

## BACKHUS

### Windrow Turner

p. 5	BACKHUS A 30
p. 6	BACKHUS A 36
p. 8	BACKHUS A 45 - 65
p. 9	BACKHUS A 75
p. 10 - 11	BACKHUS Cabin equipment
p. 12	BACKHUS Solutions

### Lane Turner

p. 13	BACKHUS LT 30 - 50
p. 14 - 15	BACKHUS LTC

## BACKHUS & CONVAERO

p. 16	BACKHUS Windrow Turner & CONVAERO System
-------	--

## CONVAERO

p. 17	Membrane System
-------	-----------------

## Eggersmann Universal shredder

p. 19	TEUTON Z 55
-------	-------------

## FORUS Pre-Shredder

p. 21	FORUS SE 250
-------	--------------

## Terra Select

### Trommel Screens

p. 25	Terra Select T 30
p. 26	Terra Select T 40
p. 27	Terra Select T 50
p. 28	Terra Select T 60
p. 29	Terra Select T 70
p. 30	Terra Select DT 60

### Windsifters

p. 31	Terra Select V 40 / V 60
p. 32	Terra Select V 70
p. 33	Terra Select W 70
p. 34	Terra Select W 80

### Star Screens

p. 35	Terra Select R 60 / R70
p. 36	Terra Select SI 60
p. 37	Terra Select HKS 50
p. 38	Terra Select S 60





Windrow Turner & Lane Turner



# BACKHUS A 30



## Easy Handling

The BACKHUS A 30 is a robust, compact and manoeuvrable turner that is easy to operate. It requires little maintenance and provides superior performance. The fully self-propelled BACKHUS A 30 is easy to transport and assures maximum flexibility. It is ideally suited for use in gardening, landscaping, fruit growing and market gardening sectors as well as for the maintenance of municipal parks and composting farmyard manure.

- Heavy-duty, compact design
- Economical diesel technology
- Height-adjustable, reversible rotor
- Fully hydraulic, low-maintenance drive
- Self-propelled, no tractor necessary - optimal utilization of space available
- Easy to transport and ready for use in no time at all
- Turning capacity up to 700 m<sup>3</sup>/h

### Dimensions



mm

length 2,600,  
width 3,550, height 1,900,  
rotor diameter 730

### Engine



**YANMAR**

Yanmar 4TNV88  
34 kW (45 PS) @ 2,400  
rpm or Yanmar 4TNV88  
35.4 kW (48 PS) @  
3,000 rpm

### Turning capacity



up to 700 m<sup>3</sup>/h

### Windrow



width: up to 3.0 m  
height: up to 1.3 m



Adjustable track clearers



Intuitive operation by hand control



Easy maintenance



Self-propelled, no tractor necessary

# BACKHUS A 36



## Attractive Price-Performance Ratio

A proven concept with short payback. The BACKHUS A 36 is a great value and an ideal entry level machine into professional composting at a very reasonable price. This turner is already one of the most efficient solutions within its class.

- High performance diesel engine with low emissions
- Simple handling and optimum ergonomics
- Compact transport dimensions
- Easy to maintain construction
- Low ground pressure for gentle turning

### Dimensions



mm

length 4,200,  
width 4,200, height 3,350,  
rotor diameter 950

### Engine



Volvo TAD 5x0 105 kW  
(143 PS) @ 1,800 rpm

### Turning capacity



up to 1,500 m<sup>3</sup>/h

### Windrow



width: up to 3.6 m  
height: up to 1.8 m



Control via  
Joystick



Easy maintenance



High performance diesel engine  
with low emissions



Simple handling and optimum  
ergonomics

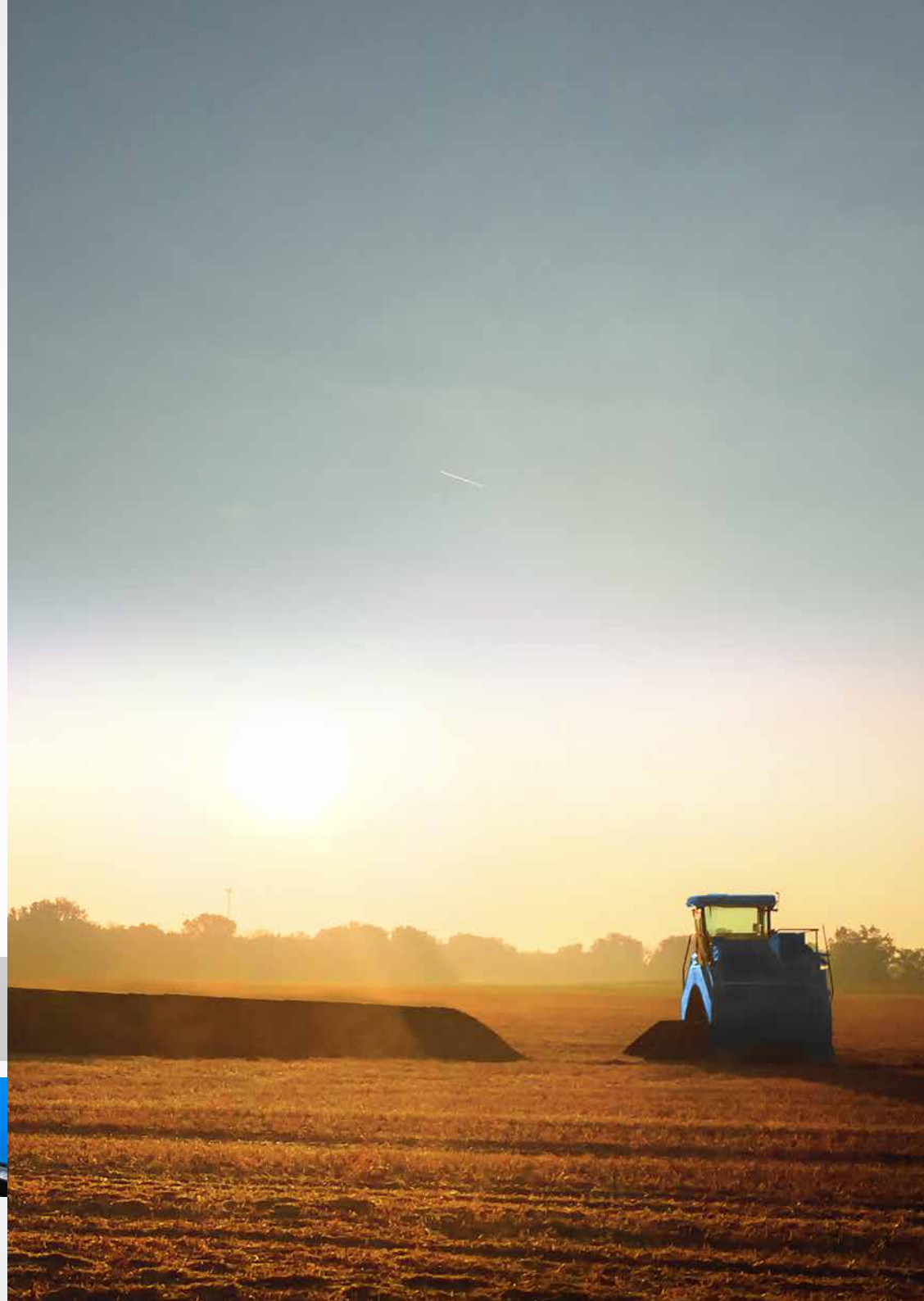



# BACKHUS A 45 - 65

## More Than Just an Option

Small fuel consumption and large turning capacities. The largest variety of options allow individual solutions for each customer. No matter what windrow width you choose, BACKHUS' low maintenance and great efficiency continue to set industry standards. Or to put it simple:

- High performance
- Low fuel consumption
- Customizable for any task
- Comfortable and easily accessible panoramic cabin
- Easy access for routine maintenance and service
- Long list of standard features
- Outstanding turning capacity up to 5,500 m<sup>3</sup>/h







# BACKHUS A 75







## Outstanding Performance

Outstanding performance is a result of cutting edge technology. With an outstanding turning capacity of up to 7,000 m<sup>3</sup>/h, extreme sturdiness and intelligent technology the BACKHUS A 75 meets all demands of modern turning. No matter what working width you may choose, your BACKHUS will set new standards in power, efficiency and handling.

- World's largest serial turner
- Long list of standard features such as load adjusting automatic speed control (BTC)
- Easily accessible panoramic cabin which combines convenience and high performance
- Easy access for routine maintenance and service
- High quality and outstanding efficiency even in the heaviest working conditions
- Strong engine - Volvo TAD 16x1 VE 450 kW (612 PS) @ 1,800 rpm

	Dimensions	Engine	Turning capacity	Windrow
	 mm	 <b>VOLVO</b>		
<b>BACKHUS A 45</b>	length 4,900, width 5,200, height 4,500, rotor diameter 1,200	Volvo TAD 5x2 VE 160 kW (218 PS) @ 1,800 rpm	up to 3,000 m <sup>3</sup> /h	width: up to 4.5 m height: up to 2.3 m
<b>BACKHUS A 50</b>	length 5,100, width 5,700, height 4,650, rotor diameter 1,200	Volvo TAD 8x3 VE 235 kW (320 PS) @ 2,200 rpm	up to 4,000 m <sup>3</sup> /h	width: up to 5.0 m height: up to 2.4 m
<b>BACKHUS A 55</b>	length 5,100, width 6,200, height 4,750, rotor diameter 1,200	Volvo TAD 8x3 VE 235 kW (320 PS) @ 2,200 rpm	up to 4,500 m <sup>3</sup> /h	width: up to 5.5 m height: up to 2.5 m
<b>BACKHUS A 60</b>	length 6,000, width 6,700, height 5,050, rotor diameter 1,400	Volvo TAD 13x3 VE 345 kW (470 PS) @ 1,900 rpm	up to 5,000 m <sup>3</sup> /h	width: up to 6.0 m height: up to 2.7 m
<b>BACKHUS A 65</b>	length 6,000, width 7,200, height 5,200, rotor diameter 1,400	Volvo TAD 13x3 VE 345 kW (470 PS) @ 1,900 rpm	up to 5,500 m <sup>3</sup> /h	width: up to 6.5 m height: up to 2.9 m

	Dimensions	Engine	Turning capacity	Windrow
	 mm	 <b>VOLVO</b>		
<b>BACKHUS A 75</b>	length 6,350, width 8,200, height 5,600, rotor diameter 1,800	Volvo TAD 16x1 VE 450 kW (612 PS) @ 1,800 rpm	up to 7,000 m <sup>3</sup> /h	width: up to 7.5 m height: up to 3.3 m



Armoured rotor tools

User-friendly maintenance and service

Low fuel consumption

Control via operation panel

Cabine with 360° panoramic view

Ground adjusting track clearers

Intelligent space utilization Side Conveyor

Control via touch panel

# BACKHUS A-series

## Cabin equipment

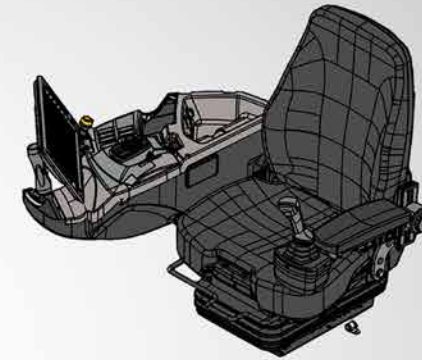

Size: 12.1" color screen (18 Bit)  
 Resolution: 1024x768  
 Backlight: LED  
 Controls: 13 keys,  
 1 cross switch with pressure function, Touchscreen

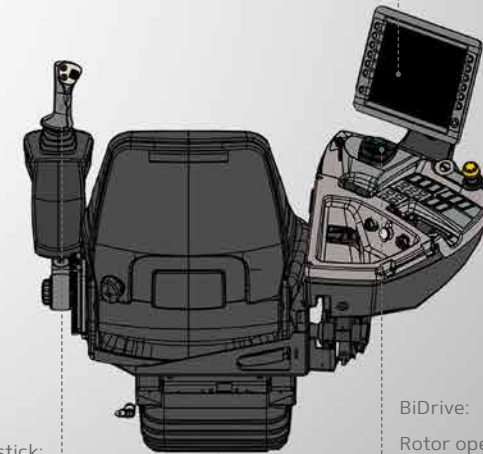

Left joystick:  
 Driving (Single-handed operation)  
 Rear tailgate  
 Engine speed  
 Wheel drive control

BiDrive:  
 Rotor operation  
 Track cleaner control

Air suspended seat



# BACKHUS Solutions

Various concepts for specific waste management and composting require specific and distinctive solutions. We offer a unique set of continuously developed project solutions for your individual concepts. You will find your personal contacts at [www.f-e.de](http://www.f-e.de).

- World's largest range of optional features
- Optimizing operating costs
- Solutions for emissions reduction
- Individual development for custom made projects
- Practical consulting and project solutions in dialogue with the customer



Automatic speed control -  
BACKHUS Track Control (BTC)



Maximum Power and Maximum Efficiency -  
BACKHUS Management System (BMS)



BACKHUS HD ME,  
Radio controlled - hose drum with 2" or 3" connection



BACKHUS HD S,  
Radio controlled - hose drum with 3" or 4" connection



In motion -  
the mobile cab



Intelligent space utilization -  
Side Conveyor



Concentrate injection tank -  
enzymes for fast composting



Process optimization -  
injecting water during turning



Reduce dust and odour -  
enclose it



For increased traction on  
loose ground -  
the landfill undercarriage



Professional optimization of  
the composting process -  
BACKHUS Fleece Winder



Half or fully automatic operation  
of turner and material flow



Armoured rotor tools



Easy access for routine  
maintenance and service



Tailor made integration into new  
or existing plants

# BACKHUS LT 30 - 50



## Forward Thinking Waste Management -

for enclosed applications and indoor plants. The BACKHUS Lane Turner incorporates the proven plant technology of BACKHUS. It offers high efficiency and turning performance and combines great economy, low maintenance and long life for composting, bioremediation and MSW treatment between lane walls or in tunnels.

- Intelligent waste management for indoor plants
- Tailor made integration into new or existing plants
- Half or fully automatic operation of turner and material flow
- Optional electronic or diesel engine
- Highly efficient material flow and batch process

Dimensions



mm

Engine



Turning capacity



Lane width,  
Material height approx.



BACKHUS  
LT 30

rotor diameter  
1,400

Electric Engine  
app. 1x11 kW (15 PS) +  
1x110 kW (150 PS)

up to 800 m<sup>3</sup>/h

width: up to 3.0 m,  
height: up to 2.0 m

BACKHUS  
LT  
45 - 50

rotor diameter  
1,800

Volvo TAD 8x3 VE  
235 kW (320 PS)  
or  
Volvo TAD 1371 VE  
285 kW (388 PS)

up to 2,000 m<sup>3</sup>/h

width: up to 4.5 - 5.0 m,  
height: up to 2.2 - 2.7 m

# BACKHUS LTC

The system for closed lane composting:

- Closed dynamic system
- Fully automated material feed and output
- Fully automated material transport within the lanes by regular turning
- Optimized oxygen supply through pressure ventilation
- Optimized water output through pressure ventilation
- Fully automated process control
- Exhaust treatment of process and hangar exhaust



Advantages of the dynamic treatment procedure compared to static procedures:

- Homogenization and aeration of the material by turning in one step
- Prevention of anaerobic areas
- Efficient moisture management during turning ensures optimum water balance
- Optimized process control and shorter treatment times

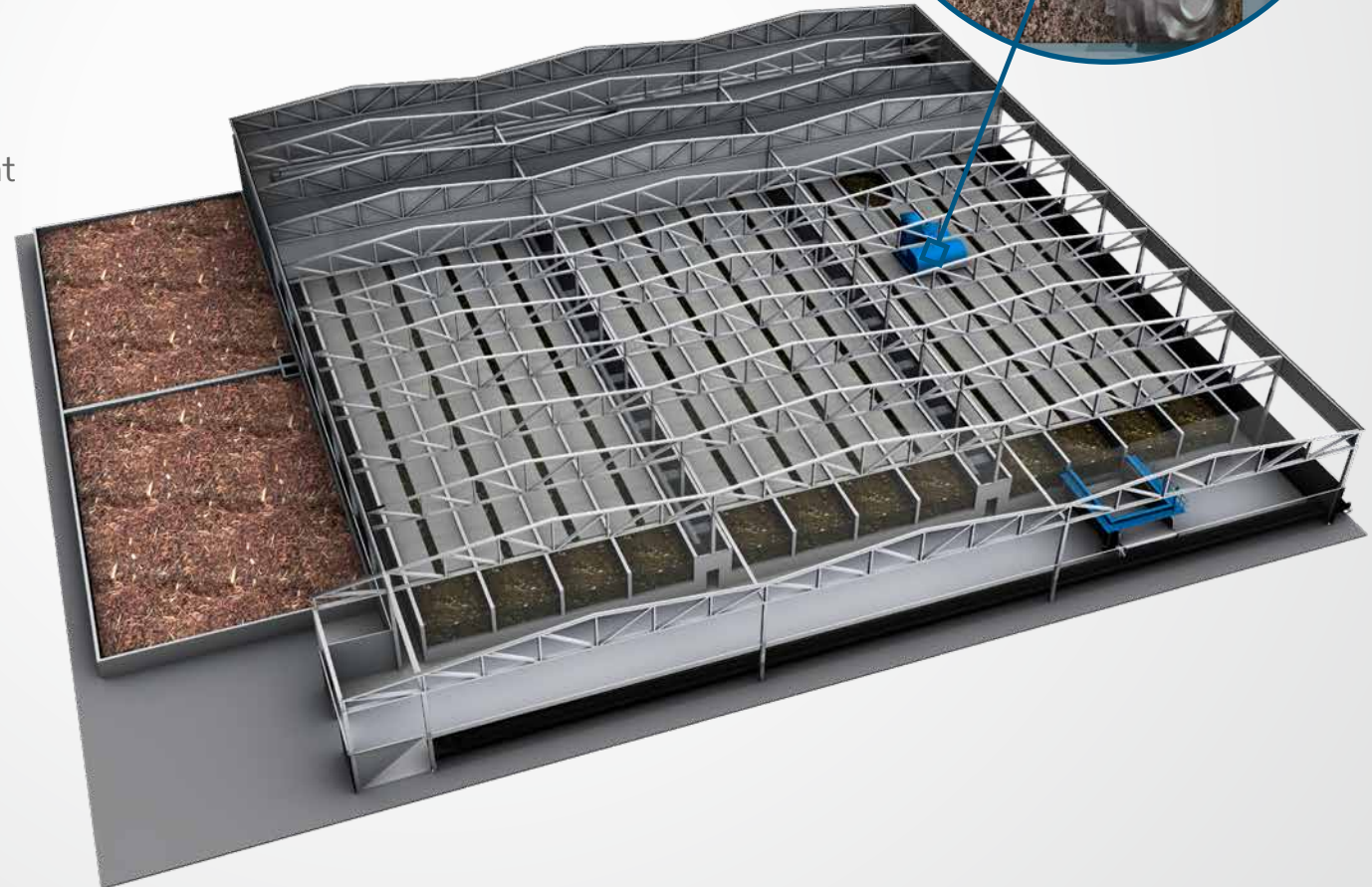



## Windrow Turner & Bio-Dry System



The best synergy: a combination of windrow turner with integrated cover winder and the membrane covered system.

Turning the covered compost windrow by a windrow turner with integrated cover winder is an almost enclosed operation. Rolling up the membrane, turning of the material, spraying of water (optional) and covering the material with the membrane again can be done simultaneously in one working step. This optimizes the process time, reduces space requirement and labour cost. High moisture content materials can be composted even when bulking agent is scarce.

BACKHUS Model BACKHUS A 50 to A 75 work seamlessly with CONVAERO System for windrow width ranging from 5.0 m to 7.5 m and windrow length up to 100 m. For higher throughput or high moisture content input material, BACKHUS CON 60, CON 75 and CON 100 are specially constructed to drive over side walls up to 1.20 m high. These models are suitable for windrow width of 6.0 m, 7.5 m and 10.0 m with a correspondingly higher volume.



## Membran-System



### CONVAERO System

The Bio-Dry process takes benefit from the natural biodegradation of organic matters by microorganism existing in waste. Special designed membrane cover is placed over waste heap, air channels in the floor provide sufficient flow of air through the waste. In this controlled and monitored environment, the microorganism decompose organic matter and heat is produced as part of the metabolic activities, which causes the temperature in the waste heap and under the cover to rise. Depending on client's requirements, the process is customized according to the purpose of waste drying or composting.

For waste drying, temperature rises to 60 - 70 degree Celsius to evaporate water in the waste. After 2 to 4 weeks, what remains of the waste is a dry, odourless and stabilized substance which is easy to handle and separate.

While for composting, temperature of 60 - 70 degree Celsius sanitizes the waste. The process is designed to provide sufficient O<sub>2</sub> to maintain aerobic condition and this creates an ideal environment for degradation of waste.

### System Features

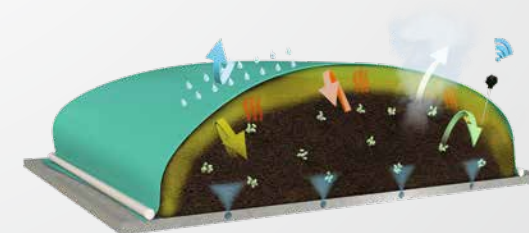

■ Wind & Rain  
 ■ Odour & volatile substances  
 ■ Heat  
 ■ Air & Vapour  
 ■ Germs



# TEUTON

Universal shredder



Waste wood



Green waste



Commercial waste

## TEUTON Z 55 – Universal shredder

The TEUTON Z 55 shreds the most diverse materials into different fractions – at maximum performance. For optimum adaptability to various tasks, the TEUTON can furthermore be equipped with many tools, counter-blades and screen baskets. This degree of flexibility has no equal on the market!

### Dimensions



mm

rotor length 3,000,  
rotor diameter 600,  
effective diameter max.  
1,050 Ø,  
number of teeth 30

### Engine



**VOLVO**

VOLVO Penta Diesel  
engine Type TAD 1375 VE,  
exhaust gas EU TIV  
or  
TIIIA

### Throughput capacity



max. 100 t/h

### Conveyor belt length, discharge height



mm

length 7,500,  
height up to 5,000



Hydraulic adjustable  
overbelt neodym magnet



Simple maintenance thanks  
to large doors



Large openings for  
material transport



TEUTON Z 55  
as track version



Tool-less  
system for quick end  
product size adjustment



High product quality  
thanks to additional  
optional screen basket



Drive unit – allows to move the  
machine using the radio remote  
(Semi-trailer only)



Easy access to the shredding  
chamber bar





## Two-Shaft-Pre-Shredder



Waste wood



Green waste



Commercial waste

### FORUS SE 250 Two-Shaft-Pre-Shredder

FORUS Pre-Shredders are specialists for all types of wood and waste – effortlessly shredding domestic waste, commercial and industrial waste, C&D waste, waste wood, green waste and rootstocks. The slow-running twoshaft-shredder also processes plastic films, paper, cardboard and electronic scrap just as efficiently. Depending on the shredding unit different rotor drives are used, from 2 x (multifunctional type, not synchronized) to 1 x (triangular knives, synchronized). The output sizes range from 150 to 500 mm depending on the type of the after breaker bar. The FORUS SE 250 is a superb all-rounder that is reliably adapted to your requirements.

#### Included special equipment:

- Hydraulic liftable and lowerable overbelt magnet
- Galvanized conveyor frame
- Breaker bar, type A1 - A4, optional
- Hydraulic liftable and lowerable after breaker bar
- Radio remote control
- Lifting hopper

#### Dimensions



mm

rotor diameter 570,  
Number of tools up to 80,  
shredding rotors  
asynchronous or optionally  
synchronous

#### Engine



Diesel motor  
185 kW – 251 PS  
or  
Electric motor 132 kW

#### Throughput capacity



max. 25 t/h

#### Discharge height



mm

height up to 3,200



Shredded green waste



Shredded plastic



Shredded wood



Shredded bulky waste





Trommel Screen Terra Select T 60



V 60 Windsifter



Z 60 Star Screen insert



Generous hopper opening for easy material infeed



High end product quality due to the optional screen basket



Easy access to the tools



Control via touch panel and remote control system



Patented locking system for the counter knife

## Terra Select T 60 Trommel Screen

High throughput performance and many innovative design solutions are the striking features of the Terra Select T 60, while its high performance motor runs fuel and energy-efficiently. The engine has sufficient power reserves to operate additional optional equipment such as star screening decks or windsifters. The pivoting infeed unit makes the daily manoeuvring of the machine easy for the personnel.



## TEUTON Z 55

### Universal shredder

With worldwide activities and years of experience in special machinery for recycling plants, we know exactly about the customers needs. The Eggersmann TEUTON Z 55 – a universal shredder for grinding wood waste, organic waste, industrial waste, tires as well as bulk trash and mattresses – is an efficient and low-maintenance universal shredder that fulfills all requirements.

Since a homogenous end product is the key to success on the worldwide markets, two shredders were often needed to reach that level in two work steps. The Eggersmann TEUTON Z 55 is able to do the pre- and re-shredding in one work cycle.



Waste wood

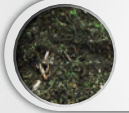

Green waste



Commercial waste

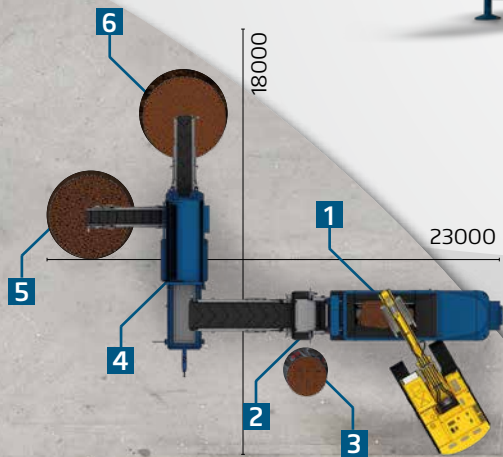

- 1 TEUTON Z 55 Universal shredder
- 2 Overbelt neodym magnet
- 3 Separated iron
- 4 Terra Select T 60 Trommel Screen
- 5 Fine fraction
- 6 Cleaned oversize fraction

## Eggersmann

Eggersmann is your provider of key machines for almost all application areas within the recycling business.

It does not matter if you need a mobile, semi-mobile or stationary solution – BACKHUS, BRT HARTNER, FORUS, Terra Select and TEUTON have the right device for your needs.

Unique feature: changeable shredding teeth



TEUTON Z 55 as track version



Hydraulic adjustable overbelt neodym magnet







# Terra Select T 30



### Small and Compact

The Terra Select T 30 Trommel Screen lends itself to being used on small composting sites, in market gardens or in rental fleets. The model is flexibly usable and therefore perfect for customers who previously hired a contractor for screening work and now want to perform this work in this sector themselves. Clarity, maintenance friendliness and the use of proven quality components from the Terra Select Trommel Screen product range provide for easy and safe handling. Good accessibility to the machine means service tasks can be performed quickly and reliably.

- The Terra Select T 30 is equipped with a 25 kW diesel motor with extremely low fuel consumption, which only uses an average of 4 l/h.
- A screening output of up to 60 m<sup>3</sup>/h can be achieved as a result of the generous fill hopper.
- The Terra Select T 30 impresses due to its large and flexible scope of application and its carefully developed inner workings — a machine with an excellent price/value ratio.

### Special features:

- Easy and simple trommel changes, low loading height, large fill hopper

#### Dimensions



mm

Working position:  
length 10,300, width 6,180  
Transport position:  
length 10,300, width 2,550

#### Engine



Diesel motor 25 kW

#### Trommel



mm

Trommel length 3,200,  
Trommel diameter 1,600,  
Effective screening area  
14.5 m<sup>2</sup>,  
Screening output  
up to 60 m<sup>3</sup>/h

#### Fine grain belt, Oversize grain belt, Hopper

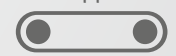

mm

length 4,100,  
width 600,  
length 3,500,  
width 600,  
Hopper 2.5 m<sup>3</sup>

# Terra Select T 40







Smaller Machine – with Technical Advantages of the »Big Machines«

For the model T 40, Terra Select compressed the technical advantages of the “big machines” and transferred them into a smaller one. As a result, it also contains the special hopper drive, a powerful diesel motor, hot dip galvanized conveyor belt frames, generous transfer points and wide conveyor belts. The Terra Select T 40 is a powerful professional machine from the compact class, almost reaching the models from the five metre class, and all of this with an excellent price/value ratio.

- The Terra Select T 40 is designed for all types of materials. It can also screen substances like earth, soil, sand, construction and demolition waste, etc. without any difficulties.
- The Terra Select T 40 is a powerful machine with compact dimensions due to its high quality equipment, its well-conceived execution and its 1,600 mm trommel diameter.

**Special features:**

- Powerful hopper belt drive, 19 m<sup>2</sup> screening area, wide conveyor belts

Dimensions	Engine	Trommel	Fine grain belt, Oversize grain belt, Hopper
 mm	 Diesel motor 55 kW	 mm	 mm
Working position: length 11,860, width 4,950 Transport position: length 9,800, width 2,550		Trommel length 4,200, Trommel diameter 1,600, Effective screening area 19 m <sup>2</sup> , Screening output up to 100 m <sup>3</sup> /h	length 3,400, width 800, length 3,400, width 800, Hopper > 3.4 m <sup>3</sup>

# Terra Select T 50





All-Rounder among the Trommel Screening Machines

The Terra Select T 50 is the all-rounder among the trommel screening machines. The Terra Select T 50 technology represents the combination between compact measurements and outstanding screening performance. Because of its adaptability and its convincing technical arguments, this model is perfectly placed in the five metre class.

- The Terra Select T 50 has a trommel diameter of 2,000 mm (normal in this class: 1,800 mm); increasing the screening performance by up to 20%.
- Accordingly, the Terra Select T 50 is equipped with a large fill hopper with a volume of more than 6 m<sup>3</sup>.
- Many of the Terra Select T 50's drive elements originated in its “big brother”, the Terra Select T 60; this ensures a long service life and provides for a higher intrinsic value.

**Special features:**

- Quiet running 55 kW diesel motor, one piece conveyor belt, trommel diameter 2,000 mm, wide conveyor belt, extra big hopper

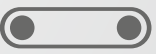
Dimensions	Engine	Trommel	Fine grain belt, Oversize grain belt, Hopper
 mm	 Diesel motor 55 kW	 mm	 mm
Working position: length 14,100, width 6,140 Transport position: length 11,200, width 2,550		Trommel length 4,500, Trommel diameter 2,000, Effective screening area 25 m <sup>2</sup> , Screening output up to 150 m <sup>3</sup> /h	length 6,700, width 1,000, length 4,900, width 1,000, Hopper > 6 m <sup>3</sup>



# Terra Select T 60







## High Throughput Performance and many Innovative Design Solutions

High throughput performance and many innovative design solutions are the striking features of the Terra Select T 60, while its high performance motor runs fuel and energy-efficiently. The engine has sufficient power reserves to operate additional optional equipment such as star screening decks or windsifters. The pivoting infeed unit makes the daily manoeuvring of the machine easy for the personnel.

- The Terra Select T 60 trommel screening machine is equipped with a powerful industrial diesel motor (75 kW power).
- The trommel, with a length of 5,500 mm and a diameter of 2,200 mm, provides for impressive screening performance of up to 200 m<sup>3</sup>/h.
- The positive fitting drive for the infeed conveyor belt stops and starts automatically depending on the amount of material in the drum, preventing an overloaded screening drum.

### Special features:

- Optional extra long fine grain belt 8,060 mm, 33 m<sup>2</sup> screening area, powerful 75 kW diesel motor

Dimensions	Engine	Trommel	Fine grain belt, Oversize grain belt, Hopper
 mm	 Diesel motor 75 kW	 mm	 mm
Working position: length 15,230, width 6,200 Transport position: length 12,000, width 2,550		Trommel length 5,500, Trommel diameter 2,200, Effective screening area 33 m <sup>2</sup> , Screening output up to 200 m <sup>3</sup> /h	length 6,700, width 1,000, length 4,900, width 1,200, Hopper > 6 m <sup>3</sup>

# Terra Select T 70







## Most Powerful, Mobile Trommel Screening Machine

The model Terra Select T 70 is the most powerful, mobile trommel screening machine in the Terra Select product range and provides for convincing throughput performance. With an impressively large screen area, it easily handles even hard-to-screen materials, such as wet compost. The long trommel and the correspondingly wide screening trommel are perfectly suited for screening all kinds of waste.

- The Terra Select T 70 achieves a screening performance of up to 250 m<sup>3</sup>/h using an effective screening area of approx. 46 m<sup>2</sup>.
- The trommel length in this model is 7,500 mm, the diameter is 2,200 mm.

### Special features:

- Impressive screening area, large fill hopper, generous infeed opening in screening drum

Dimensions	Engine	Trommel	Fine grain belt, Oversize grain belt, Hopper
 mm	 Diesel motor 75 kW	 mm	 mm
Working position: length 16,860, width 6,190 Transport position: length 13,600, width 2,550		Trommel length 7,500, Trommel diameter 2,200, Effective screening area 46 m <sup>2</sup> , Screening output up to 250 m <sup>3</sup> /h	length 6,700, width 1,000, length 4,900, width 1,000, Hopper > 6.5 m <sup>3</sup>

# Terra Select **DT 60**







## Double Trommel – for many Applications

The Terra Select DT 60 is based on the model Terra Select T 60. Its enlarged screening area makes the Terra Select DT 60 suitable for many different fields of application. This means that even two fine screenings, e. g. bark separation (0 – 10 mm, 10 – 40 mm, > 40 mm) can be screened in one step with a high throughput performance. The double trommel screening machines perform a “coarse before fine separation”; this process separates the coarse fractions in the initial step, which means that the fine screen covering the needs to screen a lower volume of material. This process ensures good throughout performance and has an excellent price/value ratio. The double trommel screening machines from Terra Select are subject to much less wear in comparison with the frequently used star screening machines in this performance class.

- The generous trommel measurements (5,500 mm long, 2,200 mm in diameter) provide for screening performance of up to 120 m<sup>3</sup>/h.
- The Terra Select DT 60 is the perfect machine for three fraction screening, e. g. biomass, shredded green cuttings, tree bark, wood chips as well as sand, stones and earth, etc.

### Special features:

- Three fractions in one step, one piece fine and medium grain belt, uses double trommel or normal Terra Select T 60 single trommel

Dimensions	Engine	Trommel	Fine grain belt, Medium grain belt, Oversize grain belt, Hopper
 mm		 mm	 mm
Working position: length 15,230, width 9,900 Transport position: length 12,000, width 2,550	Diesel motor 75 kW	Trommel length 5,500, Trommel diameter (ext.) 2,200, (in.) 1,600, Effective screening area 49 m <sup>2</sup> , Screening output up to 120 m <sup>3</sup> /h	length 6,700, width 800, length 6,700, width 1,000, length 4,900, width 1,000, Hopper > 6 m <sup>3</sup>

# Terra Select **V 40 / V 60**

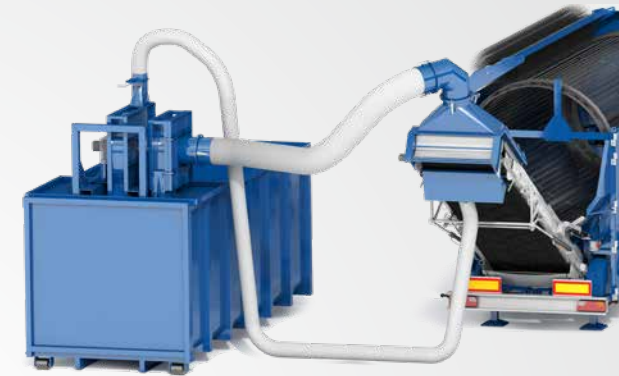



## For Continuous Cleaning of Coarse Grain Material

The Terra Select V 40 / V 60 Windsifter can be used for continuous cleaning of coarse grain material when screening with a trommel screening machine. It is fitted to the end of the coarse grain conveyor. Air is blown under the material and impurities are siphoned away. The Terra Select V 40 / V 60 Windsifter is powered hydraulically via the screening machine or electrically.

- The Terra Select V 40 and V 60 Windsifter operate with a suction/pressure fan with a capacity of 20.5 kW. This fan is mounted on the container which is filled with the impurities to be siphoned.
- The siphon unit is moved with ease using the prongs of a forklift truck or a quick-change unit.
- Applications: biomass fractions, compost, recycling materials

### Special features:

- Ease of handling, efficient, cost-effective solution

Dimensions	Engine	Suction / Pressure fan
 mm		
Working / Transport position: width 2,730, height 1,460	hydraulic via trommel screen or electric 20.5 kW	up to 20.5 kW



# Terra Select V 70



## Air Lift Separator

The Terra Select V 70 is an air lift separator, designed for the removal of paper, plastics and other light materials from compost, wood and other streams of heavy waste. The Terra Select V 70 comes in an electric model.

It works through a system of a heavy duty fan, air hose and funnel. The funnel is placed over the moving stream of waste (e.g.: conveyor belt), and filters lighter material such as paper.

The machine is standalone, placed on a frame with forklift lifting points which makes it easy to move around.

# Terra Select W 70









## For Cleaning Light Impurities out of Screen Overflows

The Terra Select W 70 Windsifter is designed for cleaning light impurities out of screen overflows in composting and biomass recycling. Impressive cleaning performances are achieved, thanks to a dedicated infeed hopper with an integrated dosing roller, and it is completely mobile. Materials which have already been screened can be cleaned of impurities completely independently of the screening machine.

- The infeed hopper is equipped with the proven positive-fitting drive system of the Terra Select trommel screens. In addition, a dosing roller ensures an even infeed of material into the machine.
- The Terra Select W 70 Windsifter impresses with a high, continuously adjustable cleaning level at throughput rates of up to 80 m<sup>3</sup>/h.
- The machine is a maintenance-friendly design, and all functions are hydraulically powered.

### Special features:

- Hopper with dosing roller, stone separation and magnet roller

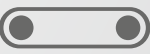
Dimensions	Engine	Suction / Pressure fan	Discharge containment	Dimensions	Engine	Suction fan, Pressure fan, Throughput	Acceleration belt, Discharge belt, Stone separation belt, Hopper
 mm				 mm			 mm
length 2,100 or 2,500, width 1,700, height 1,500	Electric motor 15 kW	up to 15 kW	Filter Sock, container	Working position: length 13,620, width 2,550, height 4,000 Transport position: length 10,560, width 2,550, height 4,000, conveyor belt length 2,700	Diesel motor 55 kW	up to 22 kW, up to 5.5 kW, up to 80 m <sup>3</sup> /h	length 3,400, width 1,300, length 3,900, width 1,000, length 2,100, width 1,000, Hopper > 4 m <sup>3</sup>

# Terra Select **W 80**







## Designed for Separating Heavy Materials

The Terra Select W 80 Windsifter is designed for separating heavy materials. For example, stones can be separated from woody materials. Wood from construction and demolition waste can be separated and used as substitute fuels using this machine. The Terra Select W 80 Windsifter is ideally equipped for use with numerous different materials.

- The infeed hopper is equipped with the proven positive-fitting drive system of the Terra Select trommel screens. In addition, a dosing roller ensures an even infeed of material into the machine.
- The Terra Select W 80 Windsifter impresses with a high, continuously adjustable cleaning level at throughput rates of up to 120 m<sup>3</sup>/h.
- The Terra Select W 80 offers easy accessibility to all components.

### Special features:

- Energy efficient direct drive, hopper with dosing roller, optional discharge conveyor for light fraction, machine control via central display

Dimensions	Engine	Pressure fan, Throughput	Discharge conveyor - heavy fraction, Hopper
 mm	 Diesel motor 75 kW	 up to 45 kW, up to 120 m <sup>3</sup> /h	 length 6,700, width 1,000, Hopper > 4 m <sup>3</sup>
Working position: length 11,960, width 6,230, height 3,770 Transport position: length 11,960, width 2,550, height 3,770			

# Terra Select **R 60 / R 70**





## Mobile Screening Panel

The mobile Terra Select R 60 or Terra Select R 70 Screening Panel is used to achieve further fractioning downstream of Terra Select trommel screening machines. The screening panel is set up behind the fine or coarse-grain conveyor and powered by the optional auxiliary drive of the trommel screening machine.

- Flexibility: 3-fraction screening if required, otherwise the full performance capability of a Terra Select trommel screening machine without the Screening Panel.
- Mobility: The Terra Select R 60 Screening Panel can be transported on the infeed hopper of a Terra Select T 50 or Terra Select T 60 using hydraulic folding supports and a mounting for the rapid changer of a suitable wheel loader.
- The Terra Select R 70 Screening Panel is ideal for achieving greater throughput rates or as an oversize grain separator, thanks to the larger screening surface. The Terra Select R 70 Screening Panel can be equipped for transporting on a hook lift platform.

### Special features:

- Cost-effective screening for further fractioning, folding supports for mobile applications

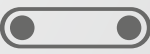
Dimensions	Engine	Screening dimensions	Conveyor belt
 mm	 electric driven or hydraulic through Trommel screen	 mm	 mm
Working position: R 60 - length 5,820, width 2,200, height 2,700 R 70 - length 5,190, width 2,400, height 2,700 Transport position: R 60 - length 3,590, width 2,200, height 1,870 R 70 - length 5,190, width 2,400, height 1,870		R 60 - length 3,300, width 1,000 R 70 - length 4,900, width 1,000	optional length 2,100, width 1,000



# Terra Select **SI 60**



## Expand Application Possibilities, Increase Flexibility

The Terra Select SI 60 Screening Panel Insert from Terra Select has been developed for the Terra Select T 60 trommel screening machine to expand its application options and increase its flexibility.

- Efficiency: Simple replacement of the screening trommel with the Screening Panel Insert enhances the screening capacity of the Terra Select T 60 for certain materials by up to 40%.
- Flexibility: Star screening technology can be used here in a trommel screening machine for applications which require greater throughput rates (e. g. for compost). Where the application purpose changes again, the Screening Insert can be removed in no time at all and the screening trommel is ready for use again.
- The Screening Insert is equipped with an aggressive dosing roller for optimum material distribution and is powered using the auxiliary drives of the screening machine.

### Special features:

- Quick changing between star screening technology and the screening trommel — one machine for every application

#### Dimensions



mm

Working and transport position:  
length 5,500, width 1,200,  
height 2,150

#### Engine



n/a  
through T60 Trommel screen

#### Throughput



up to 280 m³/h

# Terra Select **HKS 50**



## Most Complete Mobile Solution for Oversized Separation or Fine Fraction Screening

The Terra Select HKS 50 is a hook lift mobile screening machine which can be used downstream of a trommel screening machine or shredder. It can be employed as a completely mobile solution for oversize separation or fine fraction screening.

- Flexibility: The integrated optional diesel generator transforms the Terra Select HKS 50 into a completely independent screening machine. The cassette design of the screening panels ensures that the Terra Select HKS 50 is ready for quick, uncomplicated screening panel changes.
- Customer orientation: A variety of addition equipment options mean that the Terra Select HKS 50 can be optimally adapted to suit customer wishes. For example, hydraulic supports can be ordered to raise the complete screening machine. This option enables the achievement of a larger material cone under the discharging conveyors.
- The Terra Select HKS 50 achieves much more impressive screening capacities as a 2-fraction screening machine, thanks to generously dimensioned conveyor belts and a screening surface of 5.5 m².

### Special features:

- Compact design, dedicated drive for independent operation

#### Dimensions



mm

Working position:  
length 9,000, width 5,740,  
height 3,350  
Transport position:  
length 6,500, width 2,550,  
height 2,780

#### Engine



Diesel generator  
48 kVA

#### Screening dimensions



mm

length 4,600  
width 1,200

#### Fine grain belt, Coarse grain belt

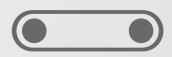

mm

length 6,100,  
width 1,000,  
length 4,100,  
width 1,340

# Terra Select S 60







## Easy Handling

Customer expectations of a recycling machine in this performance class have played a decisive role in the development of the Terra Select S 60. The wide, one-piece discharge conveyors are ideally arranged opposite to each other and facilitate movement of the machine into the working position. Large maintenance flaps provide exemplary access to the machine. A high tilting wall facilitates feeding of material into the large hopper. This prevents the material from tipping over during the loading process. The standard machine equipment meets every requirement.

- The Terra Select S 60 is extremely economical, thanks to the entirely electric drive with an optional diesel generator.
- The Terra Select S 60 Star Screen impresses through high throughput rates of up to 300 m<sup>3</sup>/h during 3-fraction screening.
- Applications: biomass, bark, waste wood, compost, wood chips

### Special features:

- Maintenance-friendly structure, fast shaft change, different steel and rubber stars available

Dimensions	Engine	Coarse screening panel, Fine screening panel, Throughput	Fine grain belt, Medium grain belt, Oversize grain belt, Hopper
 mm	 Diesel generator 72 kVA	 mm	 mm
Working position: length 12,700, width 10,950, height 3,310 Transport position: length 12,000, width 2,550, height 4,000		length 4,300, width 1,200, eff. screening area 5 m <sup>2</sup> , length 6,900, width 1,200, eff. screening area 8.3 m <sup>2</sup> , up to 300 m <sup>3</sup> /h	length 7,200, width 1,000, length 7,200, width 1,000, length 2,000, width 1,340, Hopper > 7 m <sup>3</sup>







### Eggersmann GmbH

HQ | Halle  
Ravenna-Park 2  
33790 Halle (Westf.)  
Germany

sales@f-e.de  
www.f-e.de

Technology Center | Turning  
Rothenschlatt 18  
26203 Wardenburg  
Germany

Fon +49 4407 9133-0  
Fax +49 4407 9133-101

Technology Center | Shredding  
Rothenschlatt 18  
26203 Wardenburg  
Germany

Fon +49 4407 9133-0  
Fax +49 4407 9133-101

Technology Center | Screening  
Rudolf-Diesel-Straße 11  
48336 Sassenberg  
Germany

Fon +49 2583 9197-0  
Fax +49 2583 9197-10

### Eggersmann Anlagenbau GmbH

Technology Center | Shredding  
Siegfried-Marcus-Straße 37  
17192 Waren (Müritze)  
Germany

Fon +49 3991 1723-0  
Fax +49 3991 1723-33

Carl-Zeiss-Straße 6-8  
32549 Bad Oeynhausen  
Germany

Fon +49 5734 6690-100  
Fax +49 5734 6690-140

anlagenbau@f-e.de